

# soldano

## **SUPER LEAD OVERDRIVE 100-WATT GUITAR (SLO-100) AMPLIFIER MANUAL**

Congratulations on your purchase of the legendary 100-watt Super Lead Overdrive guitar amplifier. This self-contained amp head is the finest hand-built, all-tube guitar amplifier available anywhere. Whatever your musical style, the infinite tonal variations, ease of use, versatility, and rugged, road-tested construction make it the ultimate guitar amp. It's a classic and an investment that will last a lifetime. In fact, the SLO-100 is covered by a lifetime warranty.

The SLO-100 incorporates two independent preamps, Normal and Overdrive, driven by four 12AX7/7025 tubes (five with the effects loop option). It features individual preamp gain controls and separate master volume controls with absolutely noise free channel switching. The available options for the SLO-100 include a tube-buffered effects loop and variable "slave" output.

The Normal channel offers a Clean/Crunch Switch. When set to clean, the gain is cut, providing full, clean, undistorted warmth, which is incredibly responsive and alive. When switched to crunch, the Normal channel responds with higher gain and a tough, metal edged crunch. The Bright Switch offers sparkling highs to the Normal channel adding to its versatility.

Soldano products have a lifetime warranty on workmanship (the SLO-100 warranty is transferable). Parts and labor are warranted for ten years (excluding tubes, transformers, damage, and normal wear and tear).

**WARNING: NEVER OPERATE THIS GUITAR AMPLIFIER WITHOUT SPEAKER(S) OR A SUITABLE "DUMMY LOAD" PLUGGED INTO THE SPEAKER JACK(S). FAILURE TO DO SO WILL RESULT IN DAMAGE TO THE OUTPUT TRANSFORMER AND FAILURE OF THE AMPLIFIER.**

## Operating Your SLO-100 Guitar Amplifier

1. Before plugging your SLO-100 into a power source, make sure that the Power and Standby Switches are in the 'Off' position.

### FRONT PANEL

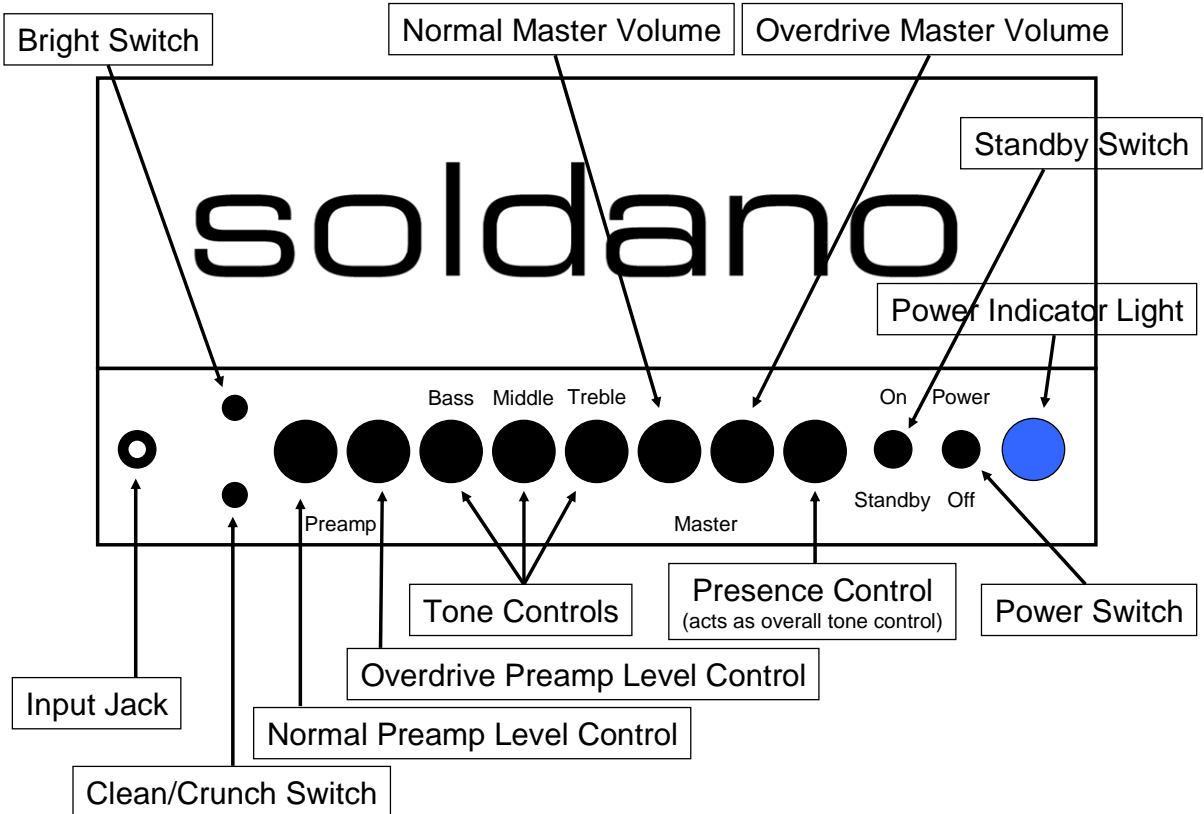

2. Make certain that the Impedance Selector is set properly (see the Chart below) and that the speaker connection(s) is/are secured from the Speaker Jack(s) to your Speaker Cabinet(s).

**WARNING: IMPROPER CONNECTIONS CAN DAMAGE THE AMPLIFIER. THE WARRANTY DOES NOT COVER DAMAGE DUE TO IMPROPER USE.**

Number of Cabinets Used	Cabinet Impedance (Ohms)	SLO Setting
1	4	4
1	8	8
1	16	16
2	8	4
2	16	8

3. Adjust the Master Volumes to Zero.

## REAR PANEL

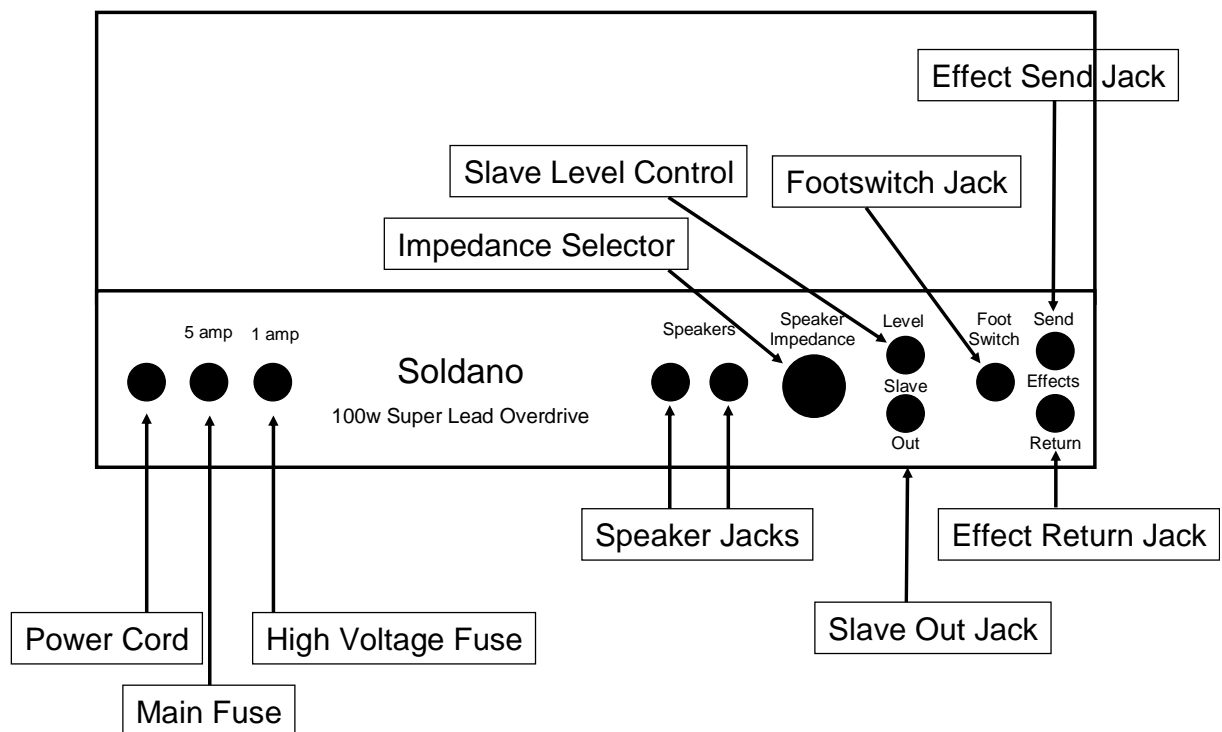

4. Plug in the Power Cord. Turn the Power Switch 'On.' Allow thirty seconds for the tubes to warm up. Connect a cord (either a speaker

cable or a guitar cord will work) from the Footswitch Jack to the Footswitch box. If the light is not lit, the normal channel will be in operation. If you are using the Effects Loop or Slave Operation, please read the sections describing them thoroughly before continuing.

5. Plug your guitar into the Input Jack and turn the Standby Switch to the 'On' position. Adjust the Master Volume, Preamp levels, and Tone controls to obtain your desired sound. For best results when switching channels, we recommend the Master Volume levels be set as close as possible.
6. When shutting down, turn off both the standby and the power. This can be done at the same time, as no waiting to cool down is necessary.

**EFFECTS LOOP OPERATION:** Plug a cord from the Effects Send Jack of the SLO-100 to the input jack of your effects unit. Plug another cord from the output jack of the effects unit to the Effects Return Jack on the SLO-100.

Note: If your effect has a switchable input or output, adjust the setting to +4dB. Refer to the effect unit owner manual for specifics.

**SLAVE OPERATION:** The slave control is an adjustable low level output taken from the output transformer to send the signal directly into a mixing board or a stereo rack system. Speaker(s), or a suitable 'dummy load,' must also be plugged in to the Speaker Jacks or the output transformer may fail.

**TUBES:** Power tubes wear out. They should be checked and serviced regularly and generally replaced annually. Our high grade preamp tubes will often give years of trouble free service and need only be replaced when necessary.

You may purchase Maximum Duty 5881 power tubes and 12AX7 preamp replacement tubes directly from us for your amplifier.

Check our website for information on tube maintenance and how to order replacement tubes ([www.soldano.com](http://www.soldano.com)).

**YOU MUST REGISTER FOR YOUR PRODUCT TO BE REGISTERED. PLEASE FILL IN THE REGISTRATION FORM AND MAIL OR FAX IT BACK TO US AS SOON AS POSSIBLE. WE ARE LOCATED AT:**

Soldano Custom Amplification  
4233 21st Avenue West  
Seattle, WA 98199  
TEL (206) 781-4636  
FAX (206) 781-5173

**WARRANTY REGISTRATION**

SOLDANO PRODUCT \_\_\_\_\_

OWNER'S NAME \_\_\_\_\_

ADDRESS \_\_\_\_\_

CITY \_\_\_\_\_

STATE \_\_\_\_\_ ZIP \_\_\_\_\_

PHONES \_\_\_\_\_

EMAIL \_\_\_\_\_

PLACE OF PURCHASE \_\_\_\_\_

SERIAL

NUMBER \_\_\_\_\_

DATE OF PURCHASE \_\_\_\_\_