

DIGITAL DELAY

SDD-3000

**OWNER'S
MANUAL**

KORG®

*Congratulations and thank you
for purchasing the Korg SDD-3000*

IMPORTANT SAFETY PRECAUTIONS

For long-term reliability and safety, please observe the following precautions and suggestions.

Location

To avoid malfunction, do not use the SDD-3000 in the following locations for long periods of time.

- ? In direct sunlight.
- ? Exposed to extremes of temperature or humidity.
- ? In dirty or dusty places,

Power supply and jacks

- ? Always be sure to use the correct AC line voltage. If line voltage is 90% or less of rated voltage, S/N ratio and stability will suffer. If you have any reason to believe the AC voltage is too low, have it checked with a voltmeter before you turn on the power supply switch.
- ? Do not use any type of plug except for standard phone plugs, (guitar type) in the input and output jacks.

Maintenance

Wipe the exterior with a soft, dry cloth. Never use benzene, paint thinner, or other solvents.

Interference from electrical appliances

Noise and interference may be picked up from radio, TV, and other electrical appliances (especially those with motors) used nearby. Should interference occur, try placing the SDD-3000 further away from the source of trouble.

Keep this owner's manual

For future reference, please store this manual in a safe place. And return your properly filled in warranty card for fullest guarantee protection.

Backup battery

The SDD-3000, once programmed, keeps the program intact even when the power switch is turned off. A built-in battery energizes the programmer when the main power is turned off.

Another advantage is that the battery is charged when the main power is on. However, if the unit is not used for over 3 months, the battery could lose its charge and programs could be accidentally erased. Therefore, if you do not use the unit for a long time, charge the battery monthly by turning on the main power for a few hours.

MAJOR FEATURES

- ? Offers a large number of versatile, high-quality effects such as flanging, doubling, chorus, vibrato, Doppler effect, slapback and echo, at the push of a button.
- ? Over 1 second delay range (0~1023 milliseconds) standard at full 17 kHz delay bandwidth.
- ? Low delay path distortion (0.03%, typical) and excellent 94 dB effect dynamic range (88 dB effect SIN ratio), without compander 'breathing' effects, through use of proprietary 13 bit audio conversion technique. Dynamic range for direct signal is 110 dB (All ratings A-weighted).
- ? Expanded Modulation section featuring 3 waveforms, envelope follower, and separate delay mod CV input. A 'random' waveform is provided for highly realistic doubling and other effects.
- ? Flexible Regeneration section, with FEEDBACK control, INVERT switch, and switchable high and low filters to create warm on metallic flanges and doubling, echoes that decay naturally, and many other unique special effects.
- ? Sophisticated programmer provides 9 different user-changeable programs plus manual setting. Programs may be copied and edited, temporarily or permanently.
- ? All major functions are fully programmable, including Delay time, Regeneration, Modulation and Effect Balance.
- ? Separate Program Up and Down footswitches may be used for instant effect selection, live or in the studio.
- ? 5 digit LED Display shows delay time setting and current program.
- ? HOLD mode provides indefinite repeats without any degradation of audio quality.
- ? Rear panel includes both Direct output and 'Sum & Difference' outputs, for rich and dramatic quasistereo doubling, flanging and chorus effects.
- ? Complete rear panel control inputs, including Delay Mod CV input and footswitch jacks for Effect Bypass, Hold, Program Up and Program Down.
- ? Input and Output jacks provided on both front and rear panels. Both inputs & front panel Output have 3 position Attenuator switches, for easy use with Instruments and in semi-pro or professional recording studios.

FEATURES & FUNCTIONS

This part of the Owners Manual is intended to provide an overview of the features & functions of the SDD-3000. Further information is contained with USING THE SDD-3000 and WHAT IS A DIGITAL DELAY.

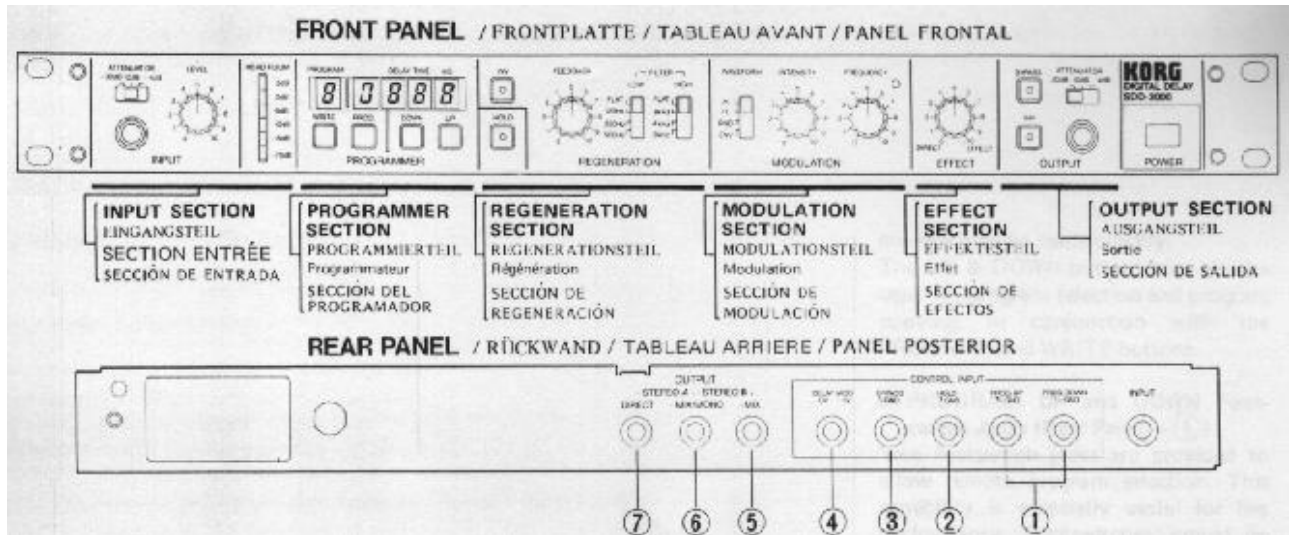

1. Input Section

The input section accepts a variety of audio signals from the outside world and adjusts their level for best noise and distortion performance.

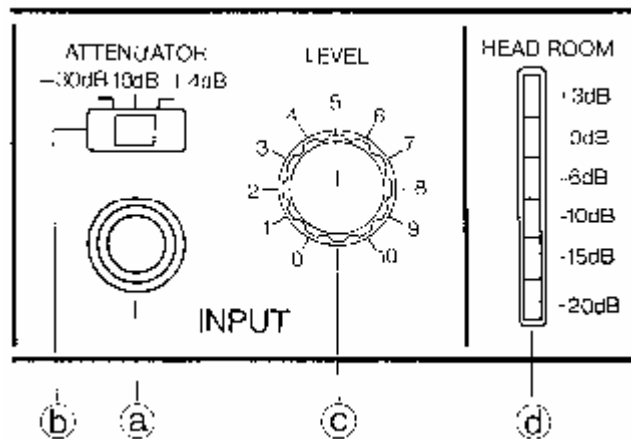

The Input Section contains the following:

- a) Front & Rear Panel Audio Input Jacks
- b) ATTENUATOR Switch
- c) Input LEVEL Control
- d) HEADROOM LED Meter

a) Audio Input Jacks

Separate input jacks are provided on the front and rear panels, for maximum convenience. If both Inputs are used the front input has priority and the rear input is internally disconnected. The two inputs are otherwise the same. Input level from either jack is affected by the input ATTENUATOR switch and LEVEL control.

b) ATTENUATOR Switch

This switch selects the basic gain and input impedance of the input stage.

It should be set to a position matching the output level of the equipment feeding the SDD-3000, in order to achieve the best dynamic range. Equipment ranging from electric guitars to professional studio mixers can be used with excellent results.

c) Input LEVEL Control

The input LEVEL control should be used to match the SDD-3000 to the actual output level of the connected equipment, once the proper range has been selected with the ATTENUATOR switch. It is very important to Set the Input level carefully, so as to reduce noise to the lowest possible level while avoiding distortion. The HEADROOM LED meter should be used to establish the proper setting.

d) HEADROOM LED Meter

The HEADROOM LED meter is calibrated in 5dB steps from -20dB to 0dB (Green LEDs), with a separate Red LED indicating +3 dB. It is used to establish proper levels and maintain good head room throughout the SDD-3000.

2. Programmer Section

Nine separate effects 'programs', or collections of control settings, may be stored, recalled and changed at will. The stored or 'programmed' settings include the delay time setting and all control settings within the Regeneration and Modulation sections.

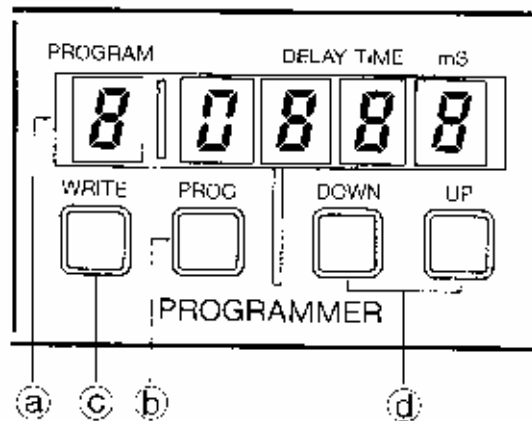

The Programmer Section Contains the following:

- a) Program & Delay Time Display
- b) PROGRAM Button
- c) WRITE Button
- d) UP & DOWN Buttons
- e) PROGRAM UP & DOWN Footswitch jacks. (Rear Panel - ⚡)

a) Program & Delay Time Display

The left-hand digit of the 5 digit LED display indicates the currently selected Program. Nine different programs may be stored and recalled in addition to the Manual setting. A "0" in the display indicates that the Manual (front panel) made is selected, while '1' - '9' indicates that one of the nine stored programs is selected.

A decimal point appears in the lower right corner of the Program Display when the currently selected program has been temporarily edited.

The four right-hand digits indicate the current basic Delay time setting. Delay time can range from 0 millisecond (0.000 second) to 1023 milliseconds (1.023 seconds), in 1 millisecond steps (.001 seconds).

b) PROGRAM Button

The primary function of the PRO-GRAM button is Program section, but it may also be used in conjunction with the WRITE button, to store a new program or permanently edit an existing one.

c) WRITE Button

The WRITE button is used to write new programs and permanently edit existing ones. A Program may be edited in place or copied into a new location, using the UP and DOWN buttons.

d) UP and DOWN Buttons

The primary function of the UP & DOWN buttons is to select a desired Delay time. An 'autoshift' function causes the Delay time to change more rapidly the longer an UP or DOWN Button Is depressed, so that large changes may be made quickly.

The UP & DOWN buttons may also be used for program selection and program copying, in conjunction with the PROGRAM and WRITE buttons.

e) PROGRAM UP and DOWN Footswitch Jacks (Rear Panel - ⚡)

Two footswitch jacks are provided to allow remote program selection This capability is especially useful for live performance. Footswitches should be Korg PS-1, S-2, or other momentary, normally open type that switches to ground when depressed.

The PROG UP Footswitch changes to the next higher program when depressed.

The PROG DOWN Footswitch changes to the next lower program when depressed.

3. Regeneration Section

The Regeneration section is used to provide repeating echoes, and to alter the tone colour of flanges, chorusing and other effects in a variety of ways.

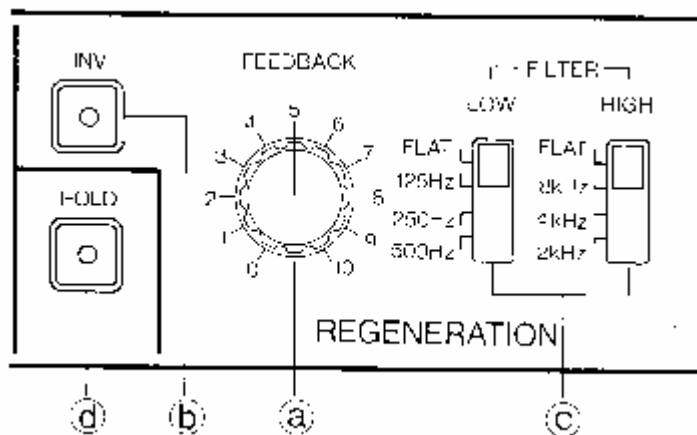

The Regeneration section includes the following:

a) FEEDBACK Control

b) INV Button

c) HIGH & LOW Filters

d) HOLD Button & Footswitch (Rear Panel - ⚡)

a) FEEDBACK Control

The FEEDBACK control determines how much (if any) of the signal coming out of the delay line is fed back into the input of the delay line, in order to produce a repeating echo or add emphasis to a flange. Feedback is also sometimes called 'Regeneration', 'Recirculation', or 'Resonance' (in a flanger).

b) INV Button

The INV button in the Regeneration section inverts the phase of the feedback loop when it is lit. It is particularly useful with flanging, chorusing, etc,

NOTE: only the feedback loop is affected by this switch, and no change will occur if FEEDBACK Is set to 0. There

is a second INV switch in the Output section, which functions differently.

c) HIGH & LOW Filter

The HIGH & LOW filters adjust the frequency response of the Delayed signal. They do not affect the response of the Direct signal. These filters are very useful in tailoring the sound to produce specific effects. These filters have a moderate effect when FEEDBACK is 0 and a greater effect as the FEEDBACK setting is increased since Feedback causes the signal to be 'recycled' through the delay me a number of times.

d) HOLD Button & Footswitch

The HOLD function provides the ability to infinitely repeat a short musical phrase, with no audio signal degradation whatsoever. When the HOLD button is depressed, the HOLD LED goes on and the 1.023 seconds of material that occurred just before the button was depressed is 'looped' internally and repeats until the HOLD button is depressed again. While the HOLD function is in effect, the Delay time and Feedback settings are 'frozen' at the maximum setting and may not be changed. However, the HIGH & LOW Filters, INV button, and all Modulation section functions may still be changed as desired. Note that if they are changed, the effects program you return to when HOLD IS released will also be changed. While HOLD is in operation, you may play new material over the repeating material. This new material will not be repeated along with the other material, since the delay line input is 'locked' to its output in HOLD mode. However, this does allow you to solo over a short musical phrase.

An optional footswitch (Korg PS-i, etc.) may be connected to the rear panel HOLD jack for remote control of the HOLD function. The HOLD button may still be used with the footswitch connected.

4. Modulation Section

The Modulation Section is used to create the modulations or variations in Delay time which are essential to most effects including flanging, chorus vibrato and doubling.

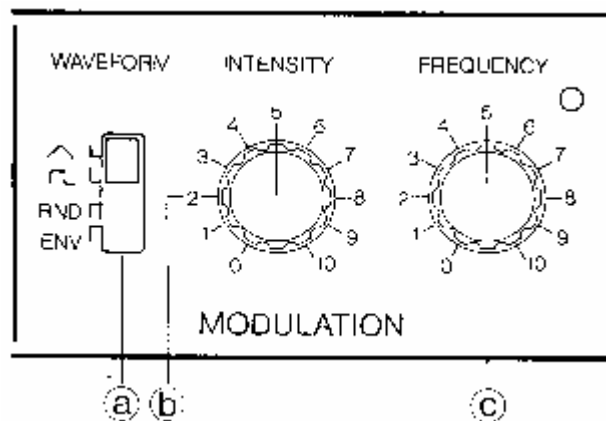

The Modulation Section includes the following:

- a) **WAVEFORM Switch**
- b) **INTENSITY Control**
- c) **FREQUENCY Control**
- d) **DELAY MOD Control Input Jack (Rear Panel - )**

a) WAVEFORM Switch

The WAVEFORM Switch determines which internal control signal is used to modulate or vary the Delay time from its basic setting. There are four possibilities (the DELAY MOD input lets you use almost anything):

1) Triangle Waveform ()

This waveform is used for effects like chorus, vibrato and flanging.

2) Square Wave

This waveform is used for special effects, such as echo with pitch shift.

3) Random (RND)

The signal produces random changes in delay time, at a rate determined by the FREQUENCY control. It is very useful for realistic doubling effects and various special effects.

4) Envelope (ENV)

The Envelope Follower causes Delay time to vary according to the amplitude envelope (volume change over time) of the audio input signal. As the volume of the sound increases, Delay time will become shorter. This is useful for Doppler effects and for touch responsive chorus and flanging effects.

b) INTENSITY Control

The INTENSITY control determines the degree (depth) to which Delay time will be affected by the selected Modulation WAVEFORM or external DELAY MOD input signal. At 0, the Delay time will remain constant at the value shown in the LED display. As the control is turned clockwise, the Delay time will begin to change; how it changes depends upon which Modulation source is selected. Modulation always causes the delay time to become shorter than the value shown in the LED Display, by a varying amount. At a control setting of 10, Delay time will vary over a range of 2:1, or from 100% to 50% of the displayed value. Thus, if the display shows a value of 1000 milliseconds, the actual Delay time will vary between 500 and 1000 milliseconds in a manner that depends upon the shape and frequency of the Modulation source.

c) FREQUENCY Control

The FREQUENCY control determines the rate or frequency of the TRIANGLE, SQUARE and RND waveforms. FREQUENCY may be varied over a range of 0.1 Hz, (1 cycle every 10 seconds) to 15 Hz. (15 cycles per second). A flashing LED indicates the current FREQUENCY setting.

d) DELAY MOD Control Input Jack (Rear Panel -)

The DELAY MOD input allows an external Control Voltage to vary the Delay time setting. This control voltage should be in the range of 0 - 5 volts; the higher the voltage, the shorter the Delay time. A KORG MS-01 or MS-04 Pedal or other voltage source may be connected. The maximum modulation depth is 2:1, depending upon the INTENSITY setting; with a 5 volt input, Delay time will be 50% of the displayed value (INTENSITY = 10). All internal modulation is disabled (switched out) when a plug is inserted into the DELAY MOD jack.

5. Effect Section

The Effect Section contains the following:

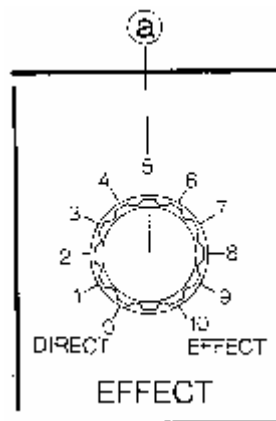

a) LEVEL BALANCE Control

The LEVEL BALANCE control determines the relative amounts of Direct and Delayed signal in the final audio output mix.

At 0, only the Direct signal will be present. At 10, only the Delayed signal will be present. Settings in between 0 and 10 will produce a continuously variable blend of the two different signals.

6. Output Section

The Output Section provides several types of mono and quasi-stereo outputs. Most of the outputs are intended for use with high-level (+4 dBm) studio and equipment, but the front panel VARIABLE Output provides a convenient interface to musical instrument amplifiers and low-level (semi-pro) PA & recording equipment as well. All outputs are unbalanced and can drive 600 ohms to full rated level (+21dBm max.).

The Output Section contains the following:

- a) **INV button**
- b) **BYPASS button & footswitch (Rear Panel - ⚡)**
- c) **ATTENUATOR switch**
- d) **VARIABLE Output Jack (Front Panel)**
- e) **DIRECT Output Jack (Rear Panel - ⚡)**
- f) **+MIX/MONO Output Jack (Rear Panel - ⚡)**
- g) **-MIX Output Jack (Rear Panel - ⚡)**

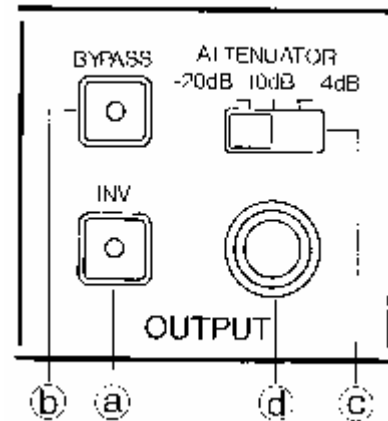

a) INV Button

The Output INVERT button inverts the phase of the Delayed signal in the output mix present at the front panel VARIABLE and rear panel +MIX/ MONO Outputs only. The INV button does not effect the -MIX Output. Changing the phase of the Output signal mix alters the tone quality of effects produced using short time delays. Normally, the VARIABLE & +MIX/ MONO Outputs provide the sum (in phase mix) of the Direct and Delayed signal. With the Output INV button depressed (LED on), these outputs provide the difference (out-of-phase mix) of the Direct and Delayed signal. The setting of the Output INV button is not programmable.

b) BYPASS Button & footswitch

The BYPASS button allows the selected effect to be turned on and off as desired. When the BYPASS LED is on, all signal outputs will provide Direct signal only, regardless of the LEVEL BALANCE setting. An optional footswitch (Korg PS-1, etc.) may be connected to the rear panel BYPASS jack for remote control of the BYPASS function. The BYPASS button may still be used with the footswitch connected.

c) ATTENUATOR Switch

The ATTENUATOR switch selects the basic or "nominal" level of the VARIABLE Output jack. It should be set to a position matching the input requirements of the equipment connected to the SDD-3000, in order to achieve best noise & distortion performance. Equipment ranging from electric guitar amplifiers to professional studio mixers can be used with excellent results. The Specifications section of this manual lists the different nominal and maximum output levels that are available.

The rear panel Output jacks are not affected by the ATTENUATOR switch, but provide a nominal output level of +4dBm at all times.

d) VARIABLE Output Jack (Front Panel)

The front panel VARIABLE Output jack provides a monaural mix of the Direct and Delayed signals, as determined by the LEVEL BALANCE and Output INV controls. The nominal level at this jack is determined by the Output ATTENUATOR switch, so that a variety of Equipment may be connected.

e) DIRECT Output Jack (Rear Panel - ⚡)

The DIRECT Output provides Direct signal only at all times, with no Delayed signal mixed in.

f) +MIX/MONO Output Jack (Rear Panel - ⚡)

The +MIX/MONO Output provides the sum (in-phase mix) or difference (Out of-phase mix) of the Direct and Delayed signal, as determined by the Output INV button. The relative balance between Direct & Delayed signal is determined by the LEVEL BALANCE control.

g) -MIX Output Jack (Rear Panel - ⚡)

The -MIX Output provides the difference (out of-phase mix) of the Direct and Delayed signals at all times. The relative balance between Direct & Delayed signal IS determined by the LEVEL BALANCE control.

USING THE SDD-3000

Three areas are contained in this section of the manual:

- 1) **Set-up & Connections**
- 2) **Using the Programmer**
- 3) **Typical Effects**

1. Setup & Connections

The following topics are covered in this section:

- A) **Input connections**
- B) **Setting Input Level**
- C) **Output Connections**
- D) **Using stereo outputs with low level equipment**
- E) **Balancing Inputs or Outputs**
- F) **Auxiliary Connections**

NOTE: All connections are made using **standard 1/4"** phone jacks.

Guitar cables or standard patch cords may be used.

NEVER connect a speaker or headphone output from an amplifier to an " jack on the SDD-3000, or serious damage may be caused to either or both units.

A) Input Connections

Either the front or back Audio Input jack may be used - whichever is more convenient. The following chart gives recommended settings:

<i>Level</i>	<i>Impedance</i>	<i>Usage</i>
-30dBm	470K Ohm	Electric Guitar, Electric Piano, other low output equipment
-10dBm	47K Ohm	Synthesizers, other Keyboards, semi-pro audio & P.A. equipment.
+4dBm	10K Ohm	Pro studio & P.A. equipment

NOTE: Since the SDD-3000 is designed to professional standards, it is assumed that users working with microphones will be using a mixer or preamp in conjunction with the SDD-3000.

B) Setting Input Level

Once the ATTENUATOR switch has been set properly, the Input LEVEL control should be adjusted carefully in order to reduce noise to the lowest possible levels while maintaining adequate headroom and avoiding distortion.

'Headroom' is the amount of room there is between the average signal level and the point at which the signal will be clipped. Since musical sounds normally fluctuate in level a good deal, it's very desirable to maintain some headroom so that occasional peaks do not cause a momentary distorted sound.

The HEADROOM Meter monitors the total signal level within the SDD-3000, and any overload within the delay system will show up on the meter. The input signal and delay feedback signal are both monitored, and the meter indicates the combined level of both signals. The signal level will rise when medium to high FEEDBACK settings are used. Therefore, INPUT level should be adjusted while listening to the actual Effect Program that you will be using.

The input LEVEL control should be adjusted so that the maximum signal generally reads around 0 dB, with the red LED lighting occasionally.

Some types of input material may require a lower average reading (-5 or -10dB) in order to prevent distortion. Although the extremely wide dynamic range of the SDD-3000 will provide good results with virtually any type of input signal, extreme cases (certain types of live vocals, percussion, etc.) may require an external limiter before the SDD-3000 for optimum results.

C) Output Connections

1) Monaural Outputs

A monaural output is typically used when two amplifiers or a stereo mix is not available. The SDD-3000 has two monaural (mono) outputs; each provides a variable mix of the Direct and Delayed signals.

a)The front panel VARIABLE Output should be used for most purposes. The nominal level at this jack is only determined by the Output ATTENUATOR switch, so that a variety of equipment may be connected, according to the following chart:

<i>Type of Equipment</i>	<i>Output ATTENUATOR Setting</i>
Musical Instrument amplifiers	-20dBm (0.075 Volts)
Semi-pro P.A. & Recording equip.	-10dBm (0.25 Volts)
Professional P.A. & Recording equip.	+4dBm (1.23 Volts)

b)The rear panel +MIX/MONO Output is generally used when the SDD-3000 is permanently installed in a studio or PA rack cabinet. The nominal level at this jack is always +4dBm.

2)Stereo Outputs

Using a Stereo output mix enhances almost any effects program by generating an extremely rich, two dimensional "sound image". Two amplifiers or a stereo PA or recording set-up are naturally required to make use of a stereo effects mix. Two types of stereo outputs are provided: the first is mono-compatible and should be used in most recording situations, while the second generates a somewhat richer effect and will generally produce better results in live performance. All stereo outputs provide a nominal +4dBm output level.

Stereo 'A'

The stereo 'A' output is produced using the DIRECT and +MIX/MONO Outputs.

The DIRECT Output should be panned all the way to one channel (or connected to one amplifier), while the +MIX/MONO Output should be panned all the way to the other channel (or connected to the second amplifier).

For maximum effect, LEVEL BALANCE should be set fairly high; some effects may require that LEVEL BALANCE = 10, with the amplifier volume controls being used to regulate the effect/direct signal balance.

This output mix should be used when making stereo recordings which may be played back in mono. It should also be used for live effects such as fully stereo echoes, when it is desired to have the direct signal come from one side of the stage with the echoes coming from the other side.

Stereo 'B'

The stereo 'B' output is produced using the +MIX/MONO and -MIX Outputs.

Each output should be fully panned to a different side of the stereo mix (or connected to a different amplifier).

The Output INV switch must be set to the normal (LED off) position.

This type of stereo output uses the sum (in-phase mix) of the Direct & Delayed signals for one side of the mix, and the differences (out-of-phase mix) of the Direct and Delayed signals for the other side of the mix.

This output mix should generally be used for live performance, as it provides the fullest sound for effects Like flanging, chorus and doubling, and also allows the LEVEL BALANCE control to be used in the normal manner.

However, it should not be used in most recording situations, since the recorded *effect* will 'disappear' whenever the recording is played back in mono, due to the phasing effect used to create the stereo image.

D) Using stereo outputs with low level equipment

Either pair of stereo outputs may be used with low level equipment such as guitar amplifiers by inserting an external 20 dB pad between each output and the corresponding amplifier input. A suitable pad may be purchased, or constructed using the following schematic. If constructed, the pads should be housed in a sturdy metal box using Switchcraft or equivalent quality 1/4" phone connectors.

20 dB Pad
20 dB-Glied
 Circuit de 20 dB
 Atenuador fijo de 20 dB

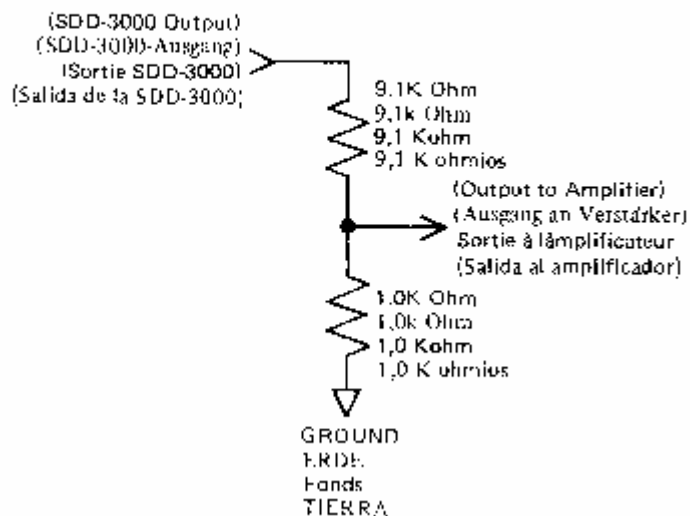

E) Balancing Inputs or Outputs

It may sometimes be necessary to balance either the input or outputs of the SDD-000, in order to prevent ground loops or to provide compatibility with pro studio or PA equipment. Since all outputs of the SDD-3000 can drive **600 ohms** directly, the use of one or more 'direct' boxes is the simplest solution.

Balancing the input requires a direct box with a balanced input and unbalanced output. The input impedance of the direct box should be determined by the nature of the input source. The 10K minimum input impedance of the SDD-3000 will accommodate almost any type of direct box.

Balancing the output(s) requires one or more direct boxes with unbalanced inputs and balanced outputs.

600 ohm - 600 ohm (1:1 ratio) direct boxes would generally be used, but higher impedances can be used if desired.

If transformer (rather than electronic) direct boxes are used, a balanced input or output may be unbalanced by simply connecting the appropriate '-' line (normally pin 2) to ground (normally pin 1), and using the '+' line (normally pin 3) as the 'HOT' connection.

F) Auxiliary Connections

Five auxiliary control inputs are provided: one Control Voltage (CV) input and four footswitch inputs.

The DELAY MOD CV input accepts an external voltage in the range of 0 to +5 volts.

Footswitches should be Korg PS-1 or S-2, or other momentary (normally open) type that switches to ground when depressed.

Detailed descriptions of the DELAY MOD input and the PROG UP, PROG DOWN, HOLD and BYPASS footswitches may be found in the Features & Functions section of the manual.

2. Using the Programmer

- A) What is a Program
- B) Selecting a Program
- C) Writing a Program
- D) Temporary Edits
- E) Permanent Edits
- F) Moving a Program

A) What is a Program

A program is a set of control settings that determine a given effect. The Delay time setting and all control and switch settings within the Regeneration, Modulation and Effect Sections are programmable - i.e., they are 'memorized' by the programmer circuitry and may be recalled at will. The HOLD and Output INV buttons are not programmable.

B) Selecting a Program

The SDD-3000 stores nine effects programs (#1-9) and has a manual mode (#0). Every time the PROGRAM button is depressed, the next higher program will be selected. In other words, if the Program display indicates program #2 is selected, pressing PROGRAM will select program #3. If program #9 is selected, pressing PROGRAM will select program #0 (Manual mode).

Lower numbered programs may be selected by holding PROGRAM down and pressing the DOWN button repeatedly, until the desired program is reached. If program #2 is selected, pressing and holding PROGRAM will select #3, at which point pressing DOWN will select #2, then #1, then #0, then #9, etc.

The PROG UP and PROG DOWN footswitches may be used to change programs in either direction directly.

C) Writing a Program

- 1) Select program #0 (manual mode). In this mode, the effect is controlled solely by the front panel settings.
- 2) Adjust controls as needed to produce the desired effect.
- 3) Decide where the new program should go. You can step through the existing program to pick which one to erase without altering or losing the effect program you just made, as long as you don't change any control settings.
- 4) Hold down the WRITE button and press the UP or DOWN button repeatedly until you reach the program # you picked in step (3).
- 5) Press the PROGRAM button while keeping WRITE depressed. This writes the new program permanently into the selected program slot, erasing the program previously at that location.
- 6) The new program may be selected at any time by selecting the appropriate program #.

D) Temporary Edits

Stored programs may be edited (changed) in any way desired. When a program is selected, the effect produced is determined solely by the stored control values for that program, and the front panel settings are ignored.

However, any changes to the front panel settings after the program is selected will alter the effect and cause the Program DISPLAY decimal point (small dot, lower right corner) to light up.

Moving a switch will simply cause the new switch position to be in effect, overriding the stored switch setting.

Moving a control will produce a 'temporary' control value that is a combination of the stored value and the amount by which the front panel control has been changed since the program was selected. For example, if FEEDBACK has a stored value of 4 and the front panel knob = 6 when the program is selected, moving the knob to 7 will produce a 'temporary' FEEDBACK value of 5. Moving the knob back to 5 will produce a 'temporary' value of 3.

Sometimes the physical endpoint of a control may be reached before the desired change has been accomplished. For example, this would happen when the stored value was 8, the front panel setting was 2, and you wanted to change the 'temporary' value of 4. If this happens, just rotate the control 1 or 2 numbers away from the endpoint. This will cause the 'temporary' value for that control to become the same as the front panel setting, and you can then select any 'temporary' value you like.

If you decide you prefer the original version of the effect, select another program and then reselect the one you edited.

E) Permanent Edits

Edits made in the above manner are temporary, and will be lost as soon as you select another program. In order to make a permanent change to a program:

- 1) Depress and hold the WRITE button.
- 2) Press PROGRAM while holding WRITE down.

This will permanently overwrite the old program with the edited version.

F) Moving an Edited Program

If you want to keep both the old program and the edited version, you can move the edited version to a new location. You must know beforehand where you want to put the edited version:

- 1) Depress and hold the WRITE button.
- 2) Press the UP or DOWN button repeatedly until the new location for the edited program is selected, while holding WRITE down.
- 3) Press PROGRAM while holding WRITE down.

3. Typical Effects Programs

This section describes a few of the many effects that are possible using the SDD-3000.

A) Flanging

Flanging requires a short delay time, medium - high feedback, and wide, smooth modulation. The HIGH & LOW

Filters may be used to emphasize different parts of the spectrum, and the Envelope Follower Is very effective with dynamic or percussive instruments such as electric guitar and electric piano. Higher FEEDBACK settings than given below will produce a more metallic, emphasized type of effect.

NOTE: At feedback settings above about 7, the SDD-3000 will begin to oscillate. This does NOT mean that there IS something wrong with the unit.

Some typical flange settings are:

? DELAYTime=3-5 milliseconds, FEEDBACK= 5, INV= On, HIGH= Flat, LOW 125Hz, WAVEFORM = TRI, INT. = 6, FREQ. = 3 LEVEL BALANCE = 5

? DELAY time = 9 milliseconds, FEEDBACK = 4.5, INV = Off , HIGH = Flat, LOW = Flat, WAVEFORM = TRI, INT.= 5, FREQ.= 3, LEVELBALANCE = 5

? DELAY time = 16 milliseconds, FEEDBACK = 4 , INV = On, HIGH = Flat, LOW = Flat, WAVEFORM = TRI, INT. = 10, FREQ. = 2, LEVEL BALANCE = 5

B) Chorus

The Chorus effects provides a gentle, rich enhancement of the sound. Delay time should be in the range of 15 -30 milliseconds. The key to a good chorus effect is to avoid detuning from excessive modulation INTENSITY or FREQUENCY. Rolling off Highs will produce a warmer, less brilliant sound.

The setting below is a good starting point:

? DELAY time 25 milliseconds, FEEDBACK = 1, INV = OFF, HIGH = Flat, LOW = Flat, WAVEFORM = TRI, INT. = 3, FREQ. = 2.8, LEVEL BALANCE = 4

C) Doubling

Doubling simulates the sound of two instruments playing together. Delay time for doubling normally ranges from 30 - 50 milliseconds. The HIGH & LOW Filters should be used to adjust the sound to taste.

The settings below are good starting points:

? DELAY Time = 33 milliseconds, FEEDBACK = 4, INV = On, HIGH = 4 kHz, LOW = Flat, WAVEFORM=TRI, INT.=3, FREQ.=2, LEVELBALANCE=4

? DELAY Time=45 milliseconds, FEEDBACK=0, INV = OFF, HIGH = Flat, LOW = Flat, WAVEFORM TRI, INT. = 8, FREQ. = 1.2, LEVEL BALANCE = 6

D) Slapback Echo

Slapback echo produces a very tight, defined sound, especially useful for filling out a rhythm part. Normally, Slapback requires a delay in the range of 50 - 150 milliseconds, but the precise delay time control! of the SDD-3000 allows the echo to be set up so that it IS exactly in step with the beat, but occurring 1/8 or 1/16 note after each note is played. Typically, this 'synchronized' Slapback will require a delay time of 200 - 300 milliseconds, depending on the basic tempo. This type of effect works best on a recording, where the delay time can be adjusted until it's right.

The FEEDBACK control determines the number of repeats and extent to which the sound is filled out. It should generally be set to 8 for the longer 'synchronized' slapbacks. LOWs can be cut for a tighter sound.

Some typical settings are:

? DELAY time = 123 milliseconds, FEEDBACK = 3, INV = OFF, HIGH = Flat, LOW = 125Hz, WAVEFORM = TRI, INT.=0, FREQ. = 0, LEVEL BALANCE =3

? DELAY time = 70 milliseconds, FEEDBACK = 2.5, INV = OFF, HIGH = Flat, LOW= 250Hz , WAVEFORM = TRI, INT. = 0, FREQ.= 0, LEVEL BALANCE 4

E) Echo

Echoes can be produced with Delay times ranging up to 1023 milliseconds (1,023 seconds). Modulation INTENSITY should be set to 0 unless special effects (such as echo with pitch shift) are desired. The FEEDBACK control is used to adjust the number of repeats. With FEEDBACK = 0, there will be only one echo repeat; as FEEDBACK is increased, so will the number of echoes. At FEEDBACK settings above about 7, the SDD-3000 will begin to oscillate. This does NOT mean that there is something wrong with the unit.

Live Overdubs

The HOLD function allows infinitely repeating echoes to be produced. However, there are two limitations: the length of the echo is fixed at 1023 milliseconds, and new material cannot be added on top of the older material. Although HOLD does provide the best sound quality, the basic fidelity of the SDD-3000 is so good that very effective and flexible 'Live overdubs' can be done using FEEDBACK alone, without HOLD.

Delay time should be at least 500 milliseconds, and FEEDBACK should be set between 6 & 7, depending on how long you want a phrase to repeat before it fades out. HIGH & LOW Filters should be Flat, and INTENSITY should be 0.

While doing a 'live overdub', play a short phrase, listen for the timing, and add additional parts as desired. These parts can be either harmony parts or bass, lead parts, etc. in different ranges from the other parts. If you want to 'erase' the live overdub and start over, press the BYPASS footswitch, watch the HEADROOM Display until it stops flickering and press BYPASS again: the SDD-3000 is now ready for another series of overdubs.

Natural Echoes

The SDD-3000 normally produces crisp, clean echoes that are very desirable in most situations. Sometimes, however, it is preferable to have echoes where the highs die off more quickly than the lows, as they do in a large room. Other times, 'pipe' echoes with no bass or extreme highs may be needed. All of these effects, and more, can be created through proper use of the HIGH & LOW Filters.

Echoes with Pitch Shift

Of course, the Delay time of an echo program can be modulated just like a flange or chorus. This produces a pitch-shifting effect that is not a true pitch transposer, but is still useful for certain special effects. The Square and Envelope Follower WAVEFORMS are most commonly used to modulate echoes, since the Square waveform will provide the most consistent and usable effect (especially at low INTENSITY settings), while the Envelope Follower will produce a predictable variation that interacts with playing style in interesting ways.

WHAT IS A DIGITAL DELAY

A digital delay is basically a device that uses digital technology to store an audio signal for a variable length of time, play it back and combine it in various ways with the original signal. It's sort of like a tape recorder, and in fact many of the most popular effects such as flanging, doubling and echo were originally done using tape recorders.

However, tape recorders present a lot of mechanical and signal degradation problems when used for effects, any they also cannot provide the kind of precise, repeatable control that is needed for best results. Analog delays were invented in order to simulate tape recorder effects with better control in a smaller package. However, noise, distortion, and high frequency response are all problems with analog delays, and long delay times with decent sound quality are next to impossible. Digital delays can provide excellent fidelity at any delay time (although not all do), with even better control and flexibility.

A simple delay line by itself isn't very interesting - it may not even be audible. What makes it interesting is the way in which the delayed signal is combined or mixed with itself and with the original signal, and the manner by which the amount of time delay is varied. It's the variation and recombination of the different signals that produces such effects as flanging, doubling, echo and Doppler shifting. Before we can consider that, however, we need to discuss a little bit about how the basic delay works.

? Lights, Camera, Action

A delay line works very much like a movie camera & projector. First, the camera takes a series of 'snapshots' of something in motion. The snapshots are stored on a continuous piece of film, one after the other. Each individual snapshot is a frozen image in which nothing moves, but when the series of 'snapshots' are played back or 'projected' in order and at the proper speed, the original image in motion is recreated.

Delay lines take snapshots or 'samples' of sound. Each sample is a measurement of exactly what the signal was doing at the particular point in time when the sample is taken. By itself, a sample doesn't mean much; it has to be combined with a lot of other samples in order for anything like a recognizable sound to be produced.

With a movie camera, the image is photographed or 'sampled' only 24 times a second. This is enough to provide a good illusion of movement, and prevent blurring, since objects that we can see don't generally move across our field of vision any faster than that. However, people with good ears can hear things that change up to 20,000 times per second - and this means that a time delay has to work pretty fast in order to reproduce sounds with good fidelity (no 'blurring'). If the unit doesn't take samples often enough, it's impossible to get good high frequency response. This is because the higher frequencies (which change the most quickly) are the ones which become 'blurred' or distorted. It turns out that the 'sampling rate' - the frequency at which samples are taken - must be at least twice as high as the highest frequency you want to reproduce, and three times higher (or more) is better.

In fact, low pass filters at the input and output of the delay line are required in order to prevent frequencies that are above the high frequency 'limit' of the system from going into the delay line or coming out of it. Without these filters, a very noticeable form of distortion will result from excessively high audio input frequencies, or from internal 'sampling rate' clock frequencies leaking into the audio signal.

? Getting Good Highs

Good high frequency response is difficult to get, partly because the circuitry must work faster, and partly because a very big memory is needed to store the enormous number of samples that good highs require. Early delay units had responses that were limited to only 6 - 8 kHz for relatively short delay times. Moreover, if you needed a longer delay time, the frequency response often dropped as low as 1 or 2 kHz! This was because the same amount of memory was used for both long and short delays, by simply changing the sampling rate.

For example if you have only 1,000 pieces of memory, or 'words', where samples can be saved, then you can get a delay of about 1/6 of a second (160 milliseconds) with a 2 kHz response and 6 kHz sample rate, or a delay of 1/24 (42

milliseconds) with an 8 kHz response and a 24 kHz sample rate - all with the same amount of memory, 42 milliseconds isn't very much time, but it's enough to do things like chorusing and flanging - although flanging with only an 8 kHz response tends to sound muffled at best.

The Korg SDD-3000 Digital Delay uses the latest 64K RAM technology to provide over 65 thousand 'words' of memory for a maximum delay time of 1023 milliseconds at full 17 kHz response. This extended delay time is a standard feature - no additional expander board is required.

? **Clarity and the fine print**

Good frequency response isn't the only important characteristic, of course - it's also necessary to reproduce sounds cleanly, with a minimum of noise and distortion. Older tape and analog delay lines added undesirable noise and distortion making it almost impossible to get clean results, especially at long delay times and/or high Feedback settings. Noise reduction or 'compander' techniques were added to the better analog delay units (as well as many digital units), in order to keep noise down to reasonable levels. Unfortunately, you can usually hear side effects from the non studio-quality noise reduction used in delay lines. One side effect is 'breathing', also called modulation noise, which is a change in the background noise level when the signal level changes. Another undesirable side effect is a definite lack of "punchiness", because noise reduction circuits generally use a compressor and this tends to take the sharp edges off of percussive sounds.

A second problem is distortion.

Tape and analog delays produce many forms of distortion, which progressively degrade the sound. Digital delays eliminate almost all of this distortion, but introduce two forms of their own. The first type is caused by putting frequencies into the delay that are higher than half the sample rate (this is why it's better to sample at 3 times the response limit, as mentioned above). This kind of distortion is called 'aliasing' or 'fold-over' distortion, and it puts a very brittle, almost "ring-modulated" edge on the sound when it occurs.

The other type of distortion produced by digital units is called 'quantizing' distortion. It's related to the fact that digital circuits turn sounds into numbers. This has a lot of advantages - numbers don't get any noisier or more distorted no matter how long they're stored, unlike analog signals. However, distortion can happen when the sound is turned into a number and back again. For example, if the circuit can handle numbers like 7, 8, 9. etc., but not anything like 7.2 or 8.65, then a audio signal with a value of 7.2 at a particular time will come out of the digital unit with a value of 7.0, and a signal that should be 8.65 will come out as 9.0. This is called 'quantizing' distortion because it occurs when a signal is turned into a number, or 'quantity'. It is a very definite, gritty-sounding kind of distortion, and it can only be avoided by making sure that the 'spaces' between the numbers (resolution) are small enough that the distortion isn't audible. This means that you have to have lots of 'bits' - the more bits, the more resolution and less distortion you have.

Having lots of bits helps with the noise problem too, because it not only improves the resolution of the numbers, it also increases the range of numbers that can be handled. This directly increases the basic dynamic range and signal/noise ratio of the system. Most digital systems use 8 - 11 bits plus noise reduction and get reasonably good result. The Korg SDD-3000 uses 13 bits of information and special proprietary technology to provide exceptional sound quality without any noise reduction circuitry and resulting undesirable side effects.

To summarise, the Key advantage of digital delays is that they turn sounds into numbers. This allows products to have much better highs, noise and distortion than analog or tape units can provide. Moreover, since numbers don't care if they get noisy the long delays and repeating echoes that drive analog and tape delays into nervous break downs aren't a problem with digital units.

? **On with the show**

Now that we have some of the technical stuff down, we can start talking about how it's all used to produce the different effects.

A basic block diagram of a delay system is shown below (A complete block diagram of the SDD-3000 is included later in this manual). It includes four important parts: 1) the delay line, 2) a way to vary or modulate the delay time, 3) a balance control which mixes the delayed and direct (unprocessed) sounds, and 4) a way to add feedback or regeneration around the delay line. The analog to digital and digital to analog converters are not shown to keep things simple.

[BLOCK DIAGRAM '1', attached.]

Let's take these parts one at a time.

Diagram 1: Basic Delay System
Diagramme 1: Vereinfachtes Verzögerungssystem
Schéma 1: Système de retard de base
Diagrama 1: Sistema de retardo básico

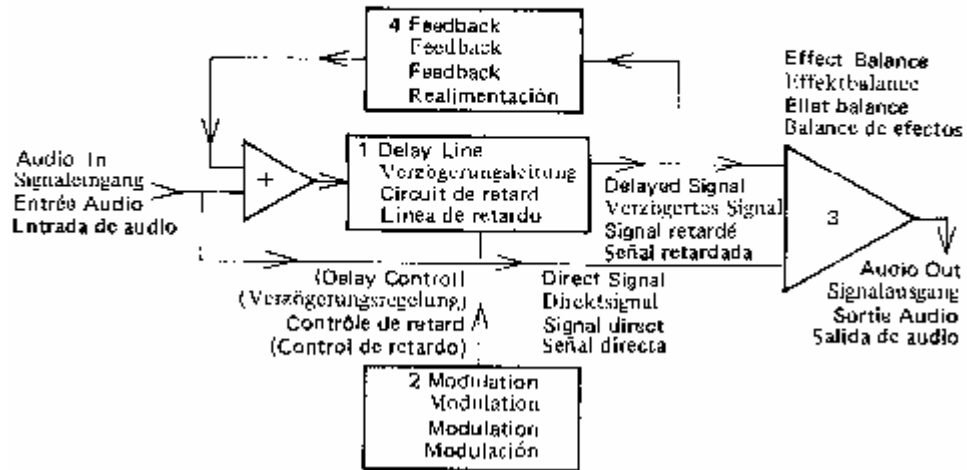

? Delay Line

The delay line was basically described above. Again, it's like a movie camera & projector. working with the same piece of film with its ends attached to form a loop. Sound samples are captured and read in by the 'camera' (analog-digital converter), stored for a certain length of time and then read out by the 'projector' (digital-analog converter). Two things determine how long the sound is stored before it's played back; the length of 'film' between the two units, which is really the number of 'frames' or samples, and the sample rate or rate at which the 'film' is moving.

[DIAGRAM OF 'CAMERA' 'FILM' & 'PROJECTOR' - DIAGRAM '2', attached]

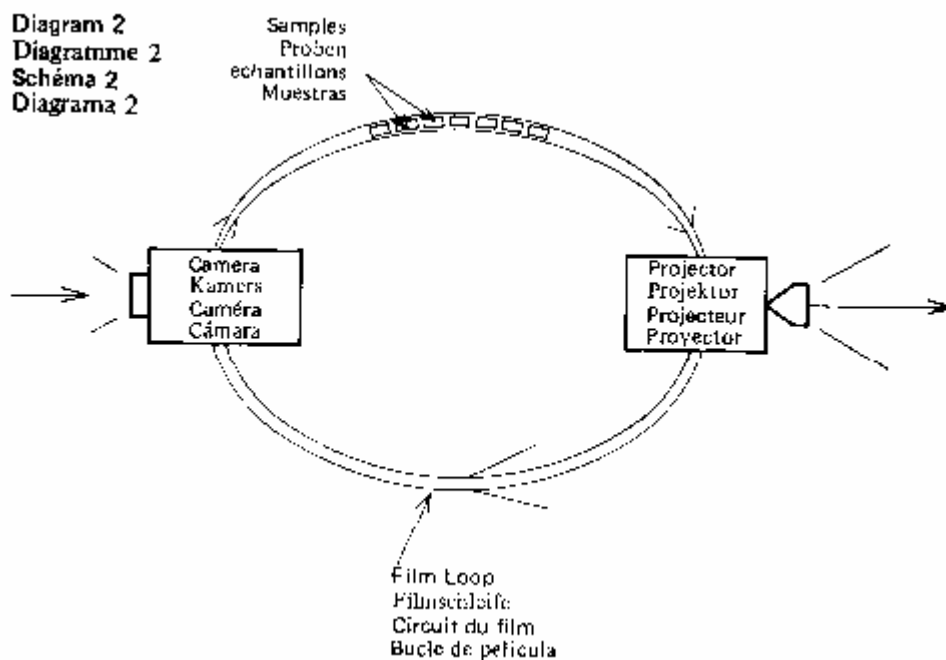

? Modulation

The delay time can be varied (modulated) in two different ways. The basic delay time is set by the number of sound

samples that are stored before the sound is 'read' out again. This is shown on the LED Display and can be varied using the UP & DOWN buttons. The basic delay time can then be varied by changing the sample rate. This is how the Modulation Section changes the delay time.

The Modulation section in the SDD3000 includes a low frequency oscillator (LFO) with two waveforms, a Random Voltage source and an Envelope Follower. Additional control sources may be connected using the Delay Mod CV input. All of these modulation possibilities allow a great many effects to be produced.

? **Effect Balance**

The balance control allows the output signal mix to be adjusted from direct (unprocessed signal only, to delayed signal only, or anywhere in between. It is basically used to control how prominent the effect will be. At short delay times (under about 50 milliseconds), mixing the direct and delayed signals will create a series of many narrow peaks and valleys in the frequency response through a process of phase cancellation. This series of peaks and valleys can create flanging effects (under about 20 milliseconds), chorusing or doubling effects (20 - 50 milliseconds), or a 'fixed equalizer' effect when no modulation is used. These peaks and valleys are most apparent when the LEVEL BALANCE control is set around 5.

? **Regeneration**

Regeneration or feedback is probably the most mysterious sounding part of a delay line, but it's actually fairly simple. All it involves is taking part of the signal coming out of the delay line and feeding it back into the input to go through the delay line again. At longer delays, adding FEEDBACK simply increases the number of repeats or echoes from 1 (with FEEDBACK = 0), to 2 or more (FEEDBACK = 1-2), to 'runaway' oscillation (FEEDBACK over about 7).

In fact, the HOLD button is just a special kind of Feedback which will 'recycle' the sound indefinitely, without losing audio quality. Even without HOLD, however, the SDD-3000 will maintain excellent signal quality after a large number of repeats. At shorter delays, the 'repeats' from feedback are so close together that you really can't hear them as repeats. Instead, they emphasize the 'peaks and valleys' character of the delayed signal and make it more resonant, or 'peakier', very much like a filter (in fact, a delay line used this way is a filter, although a very special kind). The peaks and valleys produced by a delay line occur at harmonic frequencies, just like the overtone series of a musical note, with the 'fundamental' peak being determined by the actual delay time setting. Normally, this isn't particularly audible, but when feedback is added, it becomes much more pronounced and can be used to make cymbals and other rich but unpitched sounds take on a definite pitched character. There are far more peaks and valleys in the upper part of the frequency response than in the lower part, just as overtones are packed more and more closely as you go up in the harmonic series. Adding FEEDBACK with short delays normally emphasizes higher frequencies more than lower ones, and this results in sounds that seem harder, more metallic, brittle and/or spacey. However, the Korg Digital Delay provides a pair of switcheable HIGH and LOW filters which can be used to tailor the response of the Feedback. They can be used to produce emphasized chorus and doubling effects that are warm and rounded, flanges that are exceptionally metallic or unearthly, 'natural' echoes where the highs die out first and the lows linger, and a wide variety of other pleasing sounds and unique special effects.

BLOCK DIAGRAM

[Click here to have a full view of the block diagram.](#)

SETTING CHART

1 Short delay

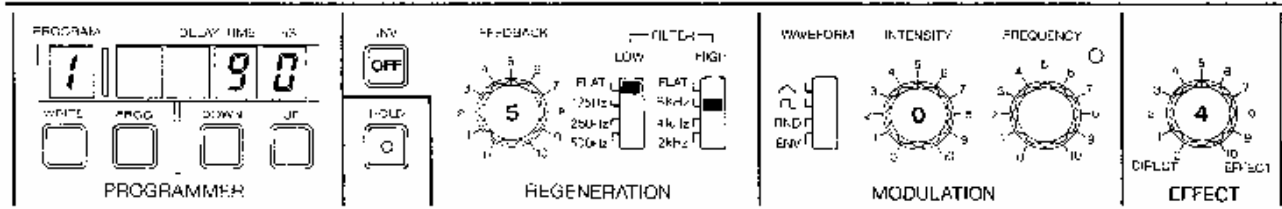

Used to obtain a normal delay effect. Adjust the feedback and delay time according to the application. Shorten the delay time to achieve a slapback effect (50 milliseconds (approximately)).

2 Long delay

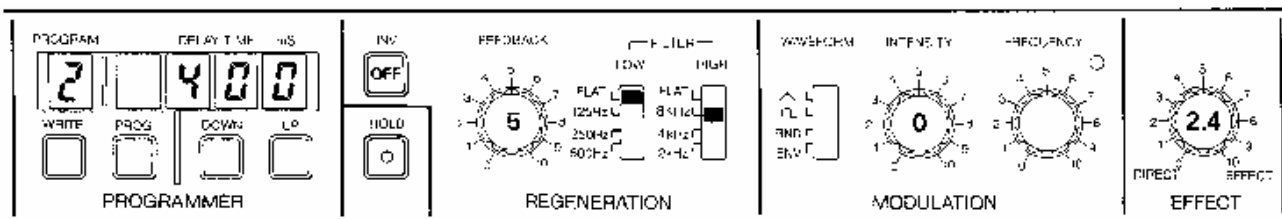

Used to obtain a long sound delay of 400 milliseconds. Longer echo effects can be obtained by increasing the delay times.

3 Doubling

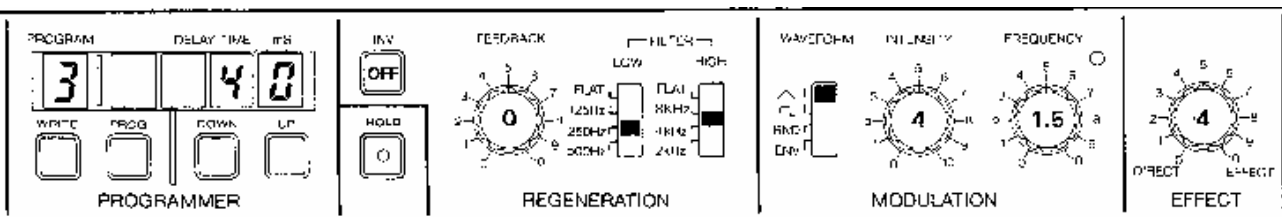

Used to obtain doubling effect on guitar chords, strings or vocal. The input is given a vibrato effect and when mixed with the original signal doubling is achieved.

4 Chorus

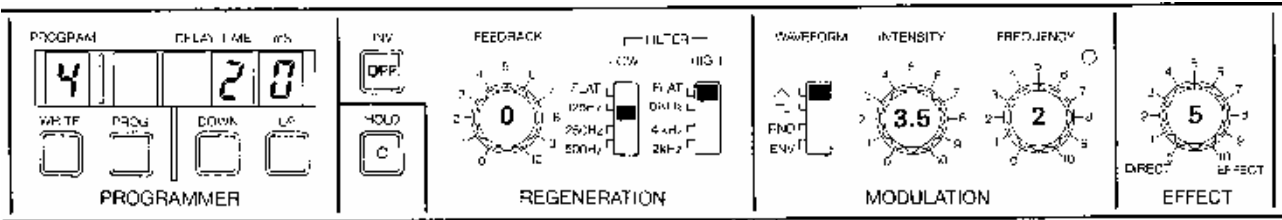

Used to obtain a normal chorus effect. Adjust the modulation intensity and Frequency according to the application.

5 Flanging

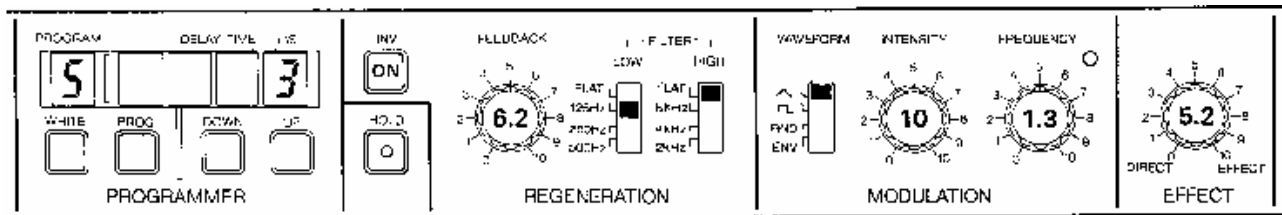

Used to obtain a flanging effect. If the feedback level is increased too much, oscillations will occur.

6 Envelope flanger

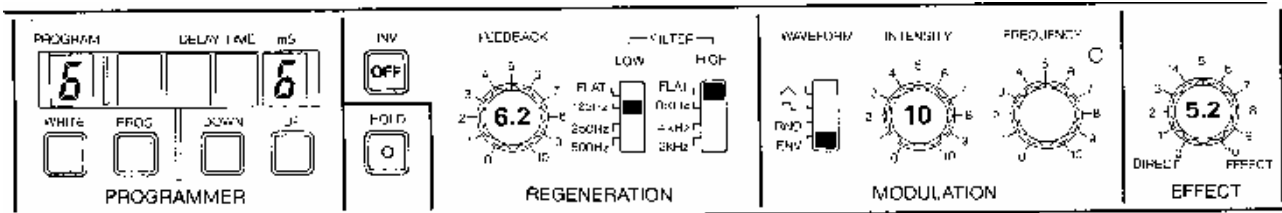

Flanging sound is achieved that is swept by the dynamics (volume level) of the input signal. Especially effective with percussive sounds (cymbal, drums, etc.).

7 Trill delay

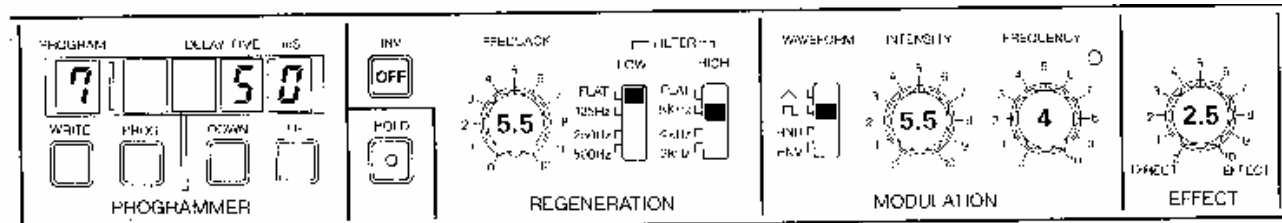

Used to obtain a trill effect. Adjust the frequency according to the tempo of the tune and adjust the intensity to achieve the proper pitch change.

8 Bending echo

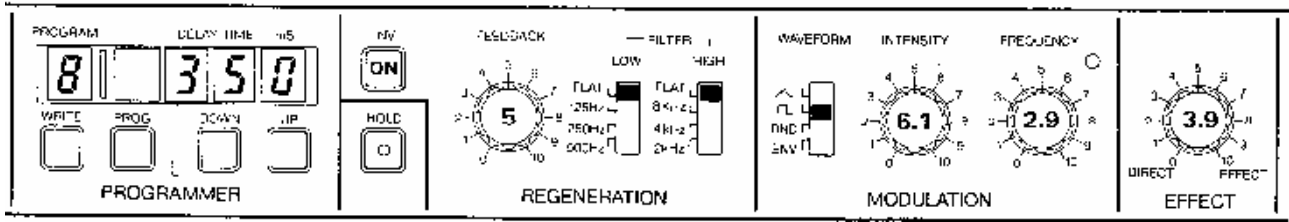

One of the trill delay effects. As the delay time is 350 milliseconds a trill effect with an echo effect can be obtained.

9 Parachute

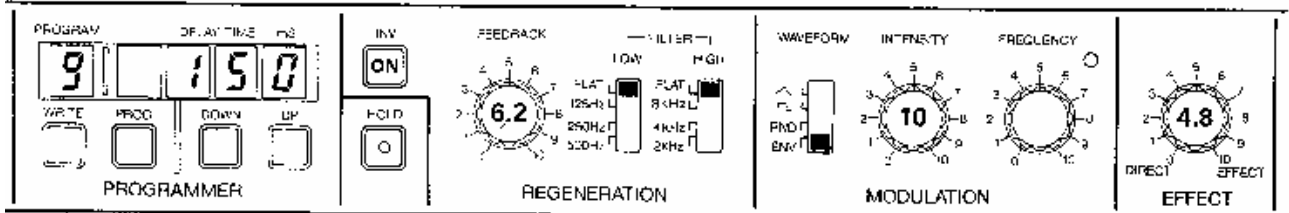

Effective when the input sound dynamic (volume level) change is large. The effect is a pitch bend with the pitch decreasing each time the echo is repeated.

OPTIONS

- ? Hard Case
- ? S-2 Dual Foot Switch
- ? MS-011 Control Pedal

19-INCH RACK MOUNTING PROCEDURE

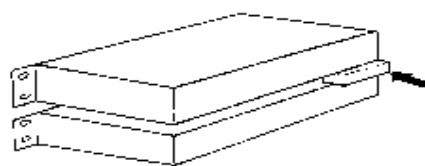
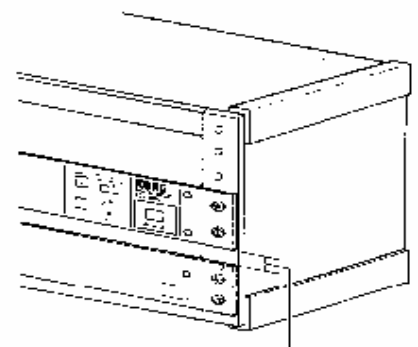
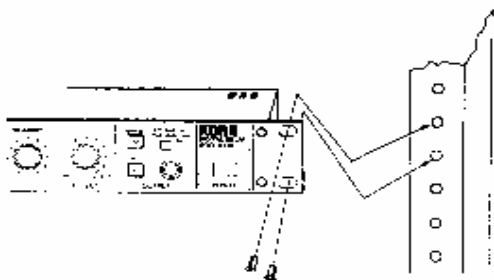

If there is a gap of about 3 mm or more, fill it in with something.

Füllen Sie Spalten von etwa 3 mm oder mehr mit einem geeigneten Material.

Si il y a un intervalle d'environ 3 mm ou plus, le remplir avec quelque chose d'autre.

Si hay una holgura de 3mm o más, proceda a llenarla.

FREQUENCY RESPONSE GRAPH

DIRECT
DIRECT / DIRECT / DIRECT

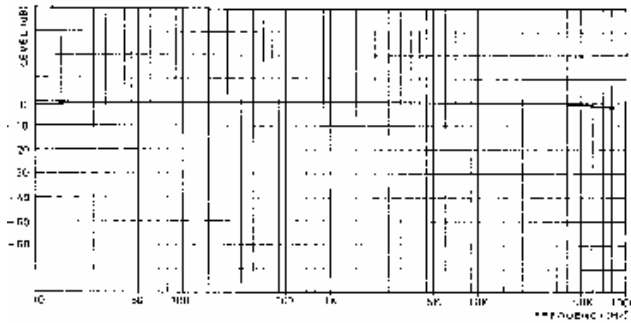

DELAY
VERZÖGERUNG / RETARD / RETARDO

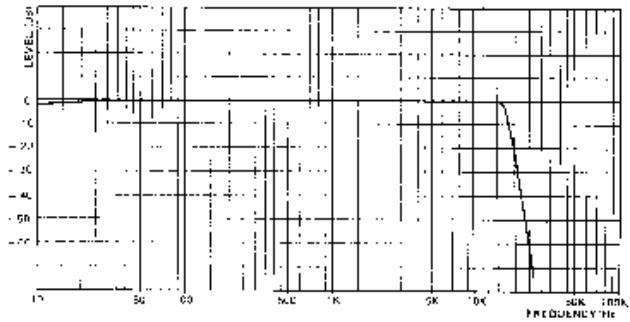

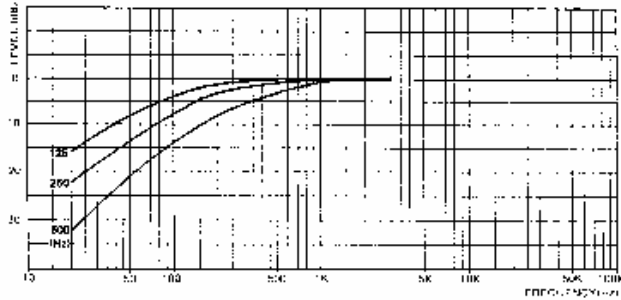

LOW CUT FILTER
RAUSCHENFILTER / FILTRE DE SUPPRESSION DES GRAVES / FILTRO DE CORTE DE BAJAS FRECUENCIAS

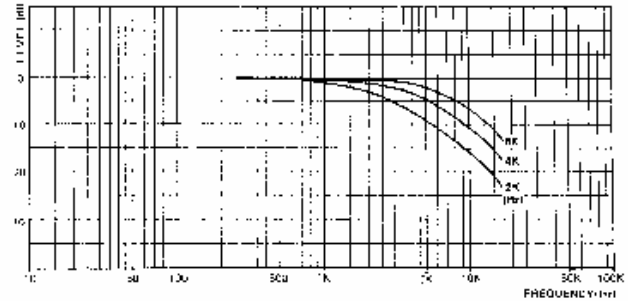

HIGH CUT FILTER
RUMPELFILTER / FILTRE DE SUPPRESSION DES AIGUS / FILTRO DE CORTE ALTAS FRECUENCIAS



SPECIFICATIONS

INPUT (0dBm = 775 mV)		Input level -30 dBm -10 dBm + 4 dBm	Impedance 470K ohm 47K ohm 10K ohm	Max (Clip) Level (Input Level at 5f) -13 dBm + 7 dBm +21 dBm
OUTPUT (0dB = 775 mV)		Output level 20 dBm -10 dBm + 4 dBm	Max (Clip) Level - 3dBm + 7 dBm +21 dBm	
FREQUENCY RESPONSE		10 ~ 20 kHz +0.5 dB, 1 dB (Direct) 10 ~ 17 kHz +0.5 dB, -3 dB (Effect)		
DYNAMIC RANGE		110 dB (Direct) A-Weighted 94 dB (Effect) A-Weighted		
S/N RATIO		95 dB (Direct) A-Weighted 88 dB (Effect) A-Weighted		
TOTAL DISTORTION		0.005% Typical at 1 kHz (Direct) 0.03% Typical at 1 kHz (Effect)		
FILTER	LOW CUT	Turn over freq. 125 Hz 250 Hz 500 Hz	Roll Off -3dB/OCT -3dB/OCT -3dB/OCT	
	HIGH CUT	8 kHz 4 kHz 2 kHz	-6dB/OCT -6dB/OCT -6dB/OCT	
MODULATION		VCO frequency range 0.1 Hz ~ 15 Hz Waveform ( ,  , Random, Envelope) Intensity (2:1 MAX.)		
DELAY TIME		0 ~ 1023 msec 1 msec step (With full bandwidth)		
DIMENSIONS		482(W) x 461(H) x 381(D) mm		
WEIGHT		6 kg		
POWER SUPPLY		Local voltage		
POWER CONSUMPTION		22W		
SUPPLIED ACCESSORIES		Dual Foot Switch S-2		Rack mounting screw X 4